











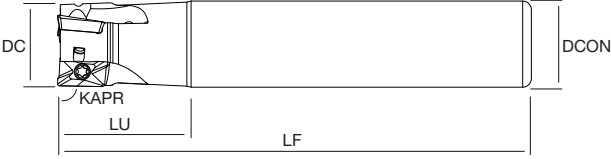

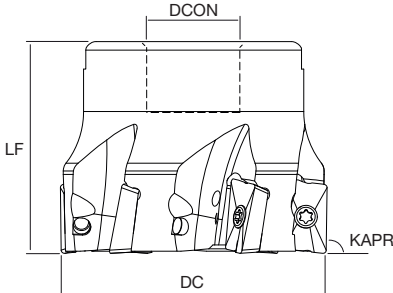

<p>CYLINDRICAL</p> 			<p>SHOULDERING</p>  90° 							
<p>INTERNAL COOLANT</p> 										
<p>ARBOR</p> 										
<p>INTERNAL COOLANT</p> 										
<p>APKT ISO Shouldering (KAPR 90°)</p>				<p>DC</p> 	<p>DCON</p>	<p>LF</p>	<p>LU</p>	<p>CRKS</p>		<p>MIID</p>

			DC		DCON	LF	LU	CRKS		MIID	
CYLINDRICAL	NT-APK10H	D016-S16-Z2	●	16	2	16	100	28	-	0.15	APKT10
		D020-S20-Z3	●	20	3	20	110	30	-	0.25	
		D025-S25-Z3	●	25	3	25	120	30	-	0.45	
		D032-S32-Z4	●	32	4	32	130	40	-	0.75	
CYLINDRICAL	NT-APK16H	D025-S25-Z2	●	25	2	25	120	40	-	0.45	APKT16
		D032-S32-Z3	●	32	3	32	130	45	-	0.75	
ARBOR	NT-APK10H	D040-F16-Z5	●	40	5	16	40	-	-	0.25	APKT10
		D050-F22-Z5	●	50	5	22	50	-	-	0.45	
		D050-F22-Z7	●		7	22	50	-	-	0.45	
	NT-APK16H	D040-F16-Z4	●	40	4	16	40	-	-	0.25	APKT16
		D050-F22-Z4	●	50	4	22	50	-	-	0.55	
		D050-F22-Z5	●		5	22	50	-	-	0.55	
		D063-F22-Z5	●		63	5	22	40	-	-	
		D063-F22-Z6	●	6		22	40	-	-	0.80	
		D080-F27-Z6	●	80		6	27	50	-	-	

● stock standard

Spare Parts	INSERT SCREW	INSERT WRENCH
		

NT-APK10H D _{□□□}	NT-ST011	NT-FTB09
NT-APK16H D _{□□□}	NT-ST019	NT-FTB15

TURNING

THREADING

GROOVING

MILLING

DRILLING

ACCESSORIES